

Carriage and Oil System

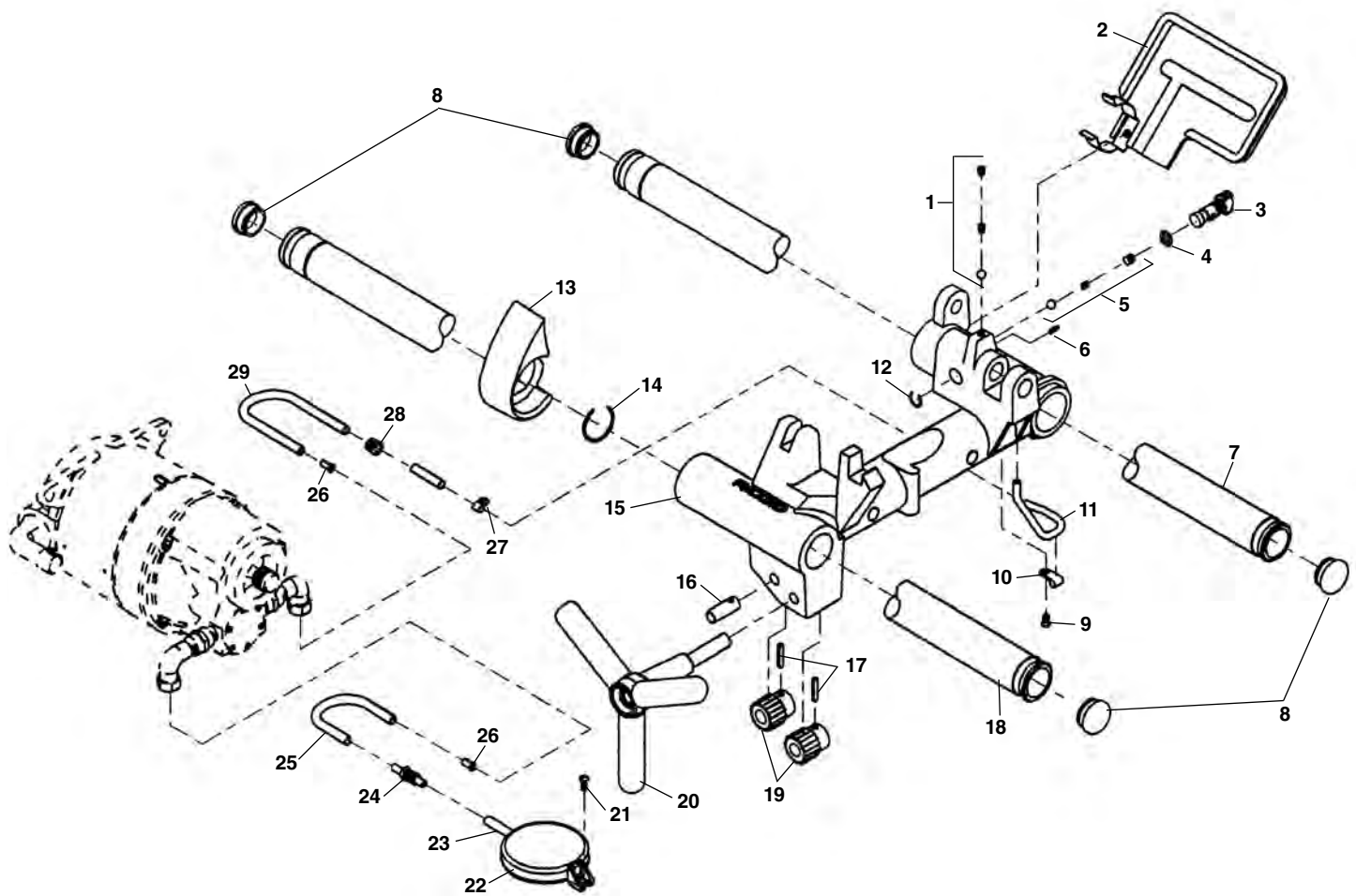

**NOTE: Order parts by Catalog Number only.
DO NOT order by Reference Number.**

<u>Ref. No.</u>	<u>Catalog No.</u>	<u>Description</u>
1	46810	Detente Assembly
2	54517	Drip Pan
3	54097	Spool Valve
4	54102	O-Ring
5	35307	Oil Pressure Relief Set
6	58417	Roll Pin 1/8" x 3/8"
7	54112	Rear Rail
8	35162	Rail Plug (4)
9	79965	Screw 10 - 32 x 1/2"
10	35062	Oil Line Clamp
11	35067	Oil Tube
12	54107	Retaining Ring
13	54507	Carriage Stop
14	87620	Retaining Ring
15	54512	Carriage
16	35187	Pinion Idler Shaft
	54122	Cap Plug (not shown)
17	34342	Roll Pin
18	54117	Front Rail
19	59092	Pinion
20	35182	Hand Wheel
21	45420	Screw 10 - 24 x 3/8"
22	58467	Filter Screen Assembly
23	61897	Oil Filter Tube
24	54142	Bulkhead Fitting
25	54152	Oil Intake Line
26	35117	Oil Line Insert
27	35142	Hose Clamp
28	47080	Oil Line Grommet
29	61282	Carriage Oil Line

Carriage and Oiling Components

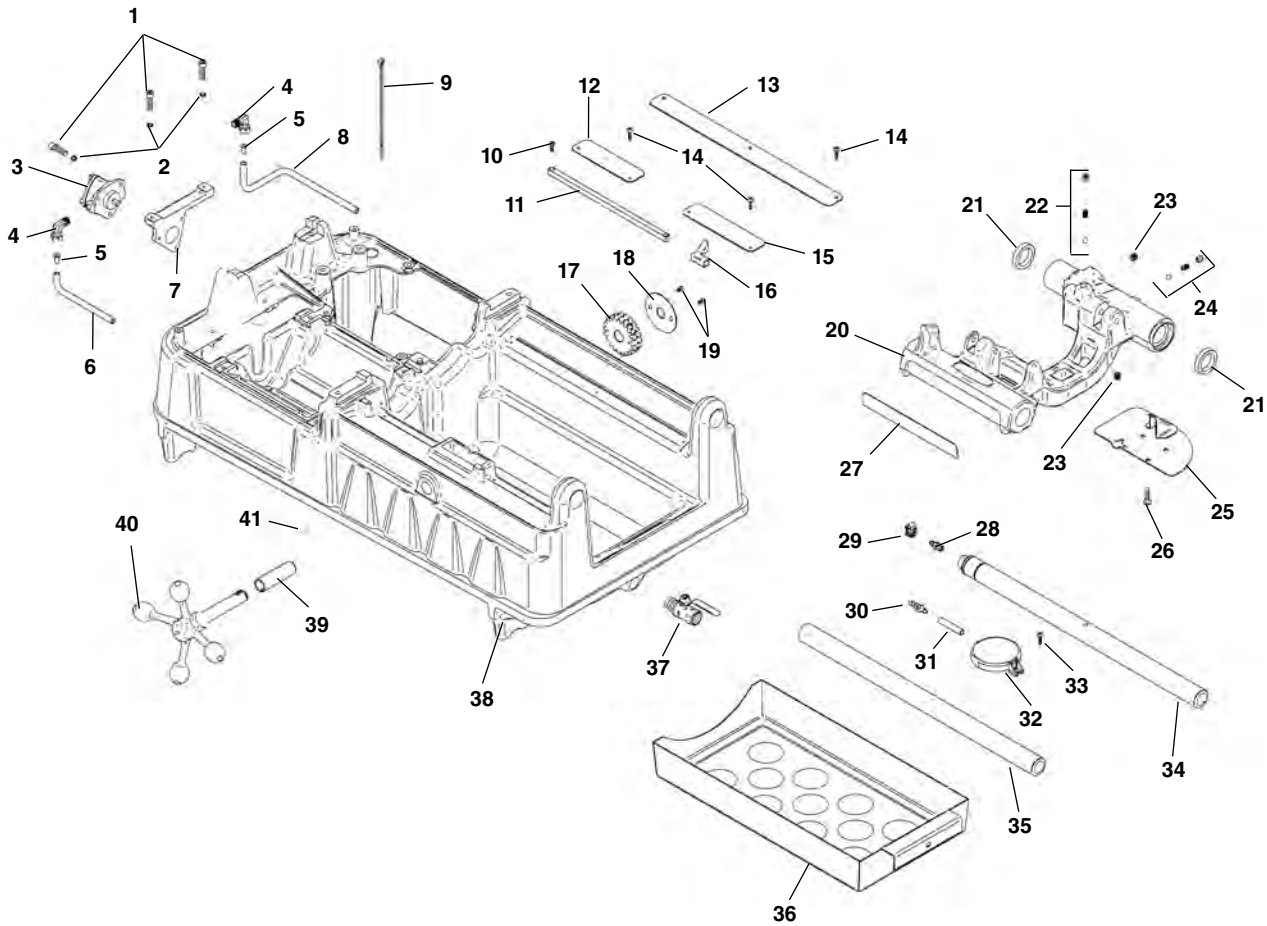

**NOTE: Order parts by Catalog Number only.
DO NOT order by Reference Number.**

Ref. No.	Catalog No.	Description	Ref. No.	Catalog No.	Description
1	83685	Screw, Socket Head 1/4" - 20 x 1" (5)	22	46810	Die Head Détente
2	44740	Lock Washer, 1/4" (5)	23	46815	Pipe Plug, 1/8" NPT (2)
3	94092	Oil Pump	24	35307	Pressure Relief Set
4	35122	Fitting (2)	25	45195	Drip Tray
5	35117	Tube Insert	26	46270	Screw, 1/4" - 20 x 1/2" (4)
6	26822	Oil Hose	27	46370	Length Gauge
7	27123	Oil Pump Bracket	28	69157	Barbed Fitting
8	94362	Oil Hose	29	35142	Hose Clamp
9	94407	Cable Tie	30	54142	Bulkhead Fitting
10	45615	Screw, Flat Head #10 - 32 x 1/2" (2)	31	87950	Hose
11	47105	Length Indicator Bar	32	58467	Filter Screen Assembly
12	94122	Drip Edge	33	45420	Screw, #10 - 32 x 3/8"
13	94127	Drip Edge	34	45220	Support Bar, Rear
14	43367	Screw, #8 x 3/4"	35	45440	Support Bar, Front
15	94117	Drip Edge	36	94112	Chip Tray
16	47110	Indicator Slide	37	94347	Valve, Oil Drain
17	45430	Pinion	38	94042	Base
18	47120	Pinion Lock Ring	39	94222	Bushing
19	46785	Screw, Flat Head #10 - 32 x 3/8" (2)	40	94012	Handwheel
20	94357	Carriage Assembly (Includes Ref. Nos. 21 - 27)	41	94267	Key, 3/16" Square x 1/2"
21	46720	Oil Seal (2)			

Carriage and Oiling Components – Universal Motor Machines

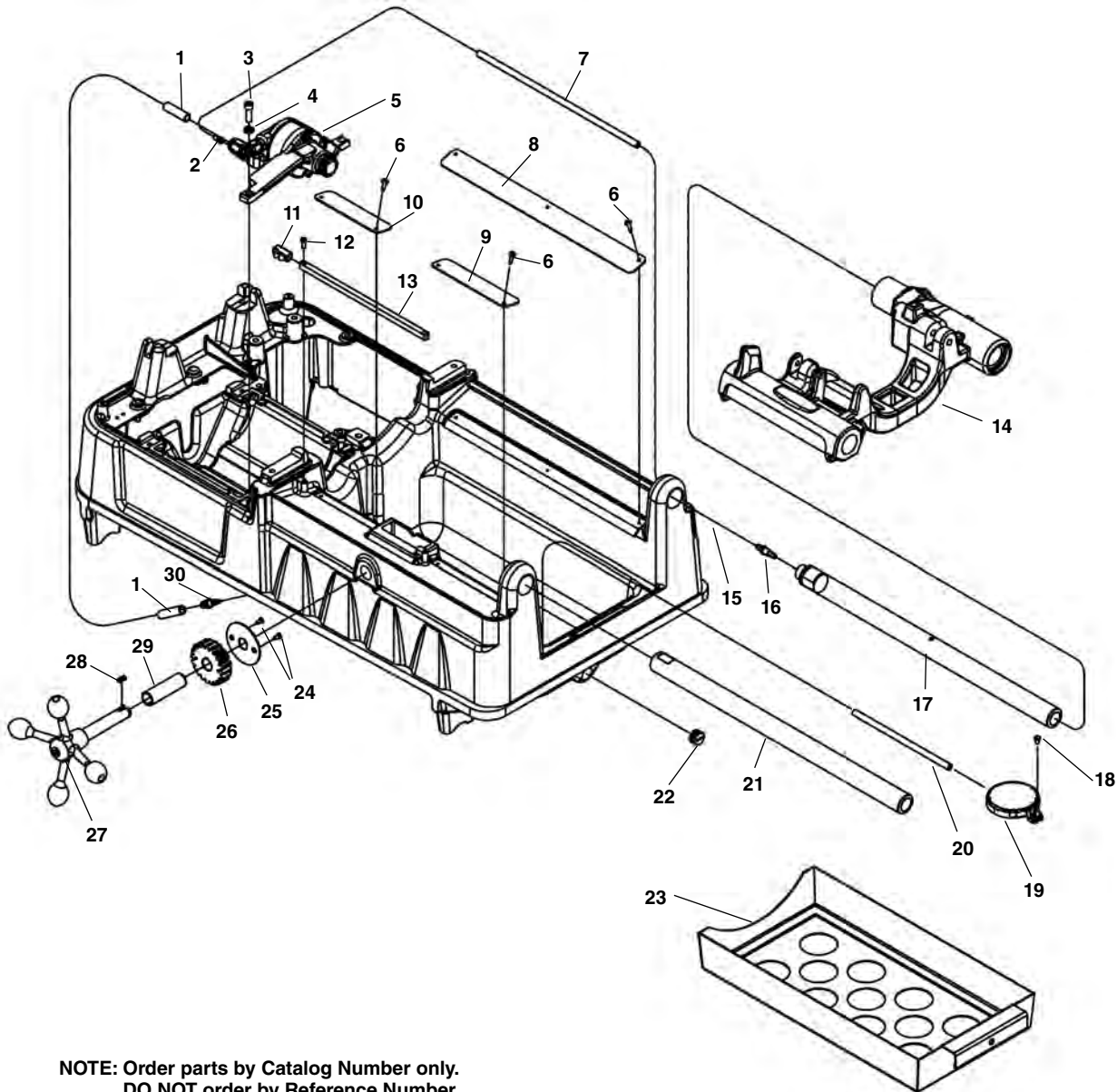

**NOTE: Order parts by Catalog Number only.
DO NOT order by Reference Number.**

Ref. No.	Catalog No.	Description	Ref. No.	Catalog No.	Description
1	26822	Oil Hose, Input 21"	16	69157	Barbed Fitting
2	35117	Tube Insert	17	45220	Support Bar, Rear
3	44590	Screw, $\frac{5}{16}$ " - 18 x 1" S.H.C.S.	18	45420	Screw, #10 - 32 x $\frac{3}{8}$ "
4	40770	$\frac{5}{16}$ " Lock Washer	19	58467	Filter Screen Assembly
5	96517	Oil Pump	20	87950	Oil Hose, Filter
6	43367	Screw, #8 x $\frac{3}{4}$ "	21	45440	Support Bar, Front
7	94362	Oil Hose, Output	22	96447	Drain Plug $\frac{1}{2}$ " NPT
8	94127	Drip Edge	23	94112	Chip Tray
9	94117	Drip Edge	24	46785	Screw, Flat Head #10 - 32 x $\frac{3}{8}$ " (2)
10	94122	Drip Edge	25	47120	Pinion Lock Ring
11	47110	Indicator Slide	26	45430	Pinion
12	45615	Screw, Flat Head #10 - 32 x $\frac{1}{2}$ " (2)	27	94012	Handwheel
13	47105	Length Indicator Bar	28	94267	Key, $\frac{3}{16}$ " Square x $\frac{1}{2}$ "
14	94357	Carriage Assembly	29	94222	Bushing
15	35142	Hose Clamp	30	54142	Bulkhead Fitting

Oiling Components

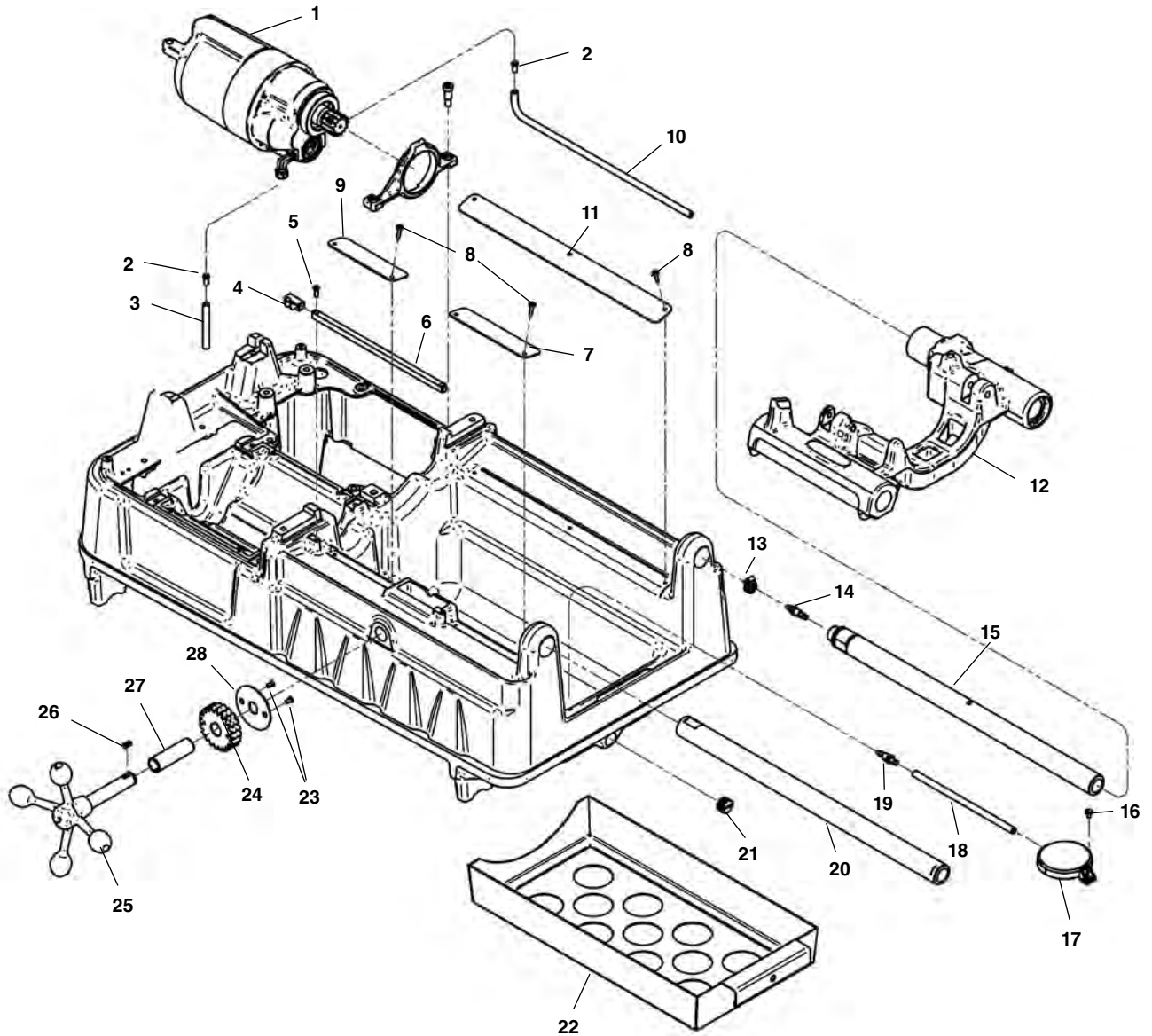

**NOTE: Order parts by Catalog Number only.
DO NOT order by Reference Number.**

Ref. No.	Catalog No.	Description	Ref. No.	Catalog No.	Description
1	96442	1101 Motor Assembly 115V	15	45220	Support Bar, Rear
	21208	2301 Motor Assembly 230V	16	45420	Screw, #10 - 32 x 3/8"
2	35117	Tube Insert	17	58467	Filter Screen Assembly
3	97950	Oil Hose, Input 13"	18	87950	Oil Hose, Filter
4	47110	Indicator Slide	19	54142	Bulkhead Fitting
5	45615	Screw, Flat Head #10 - 32 x 1/2" (2)	20	45440	Support Bar, Front
6	47105	Length Indicator Bar	21	96447	Drain Plug 1/2" NPT
7	94117	Drip Edge	22	94112	Chip Tray
8	43367	Screw, #8 x 3/4"	23	46785	Screw, Flat Head #10 - 32 x 3/8" (2)
9	94122	Drip Edge	24	45430	Pinion
10	58482	Oil Hose, Input 25"	25	94012	Handwheel
11	94127	Drip Edge	26	94267	Key, 3/16" Square x 1/2"
12	94357	Carriage Assembly	27	94222	Bushing
13	35142	Hose Clamp	28	47120	Pinion Lock Ring
14	69157	Barbed Fitting			

Carriage and Oil System

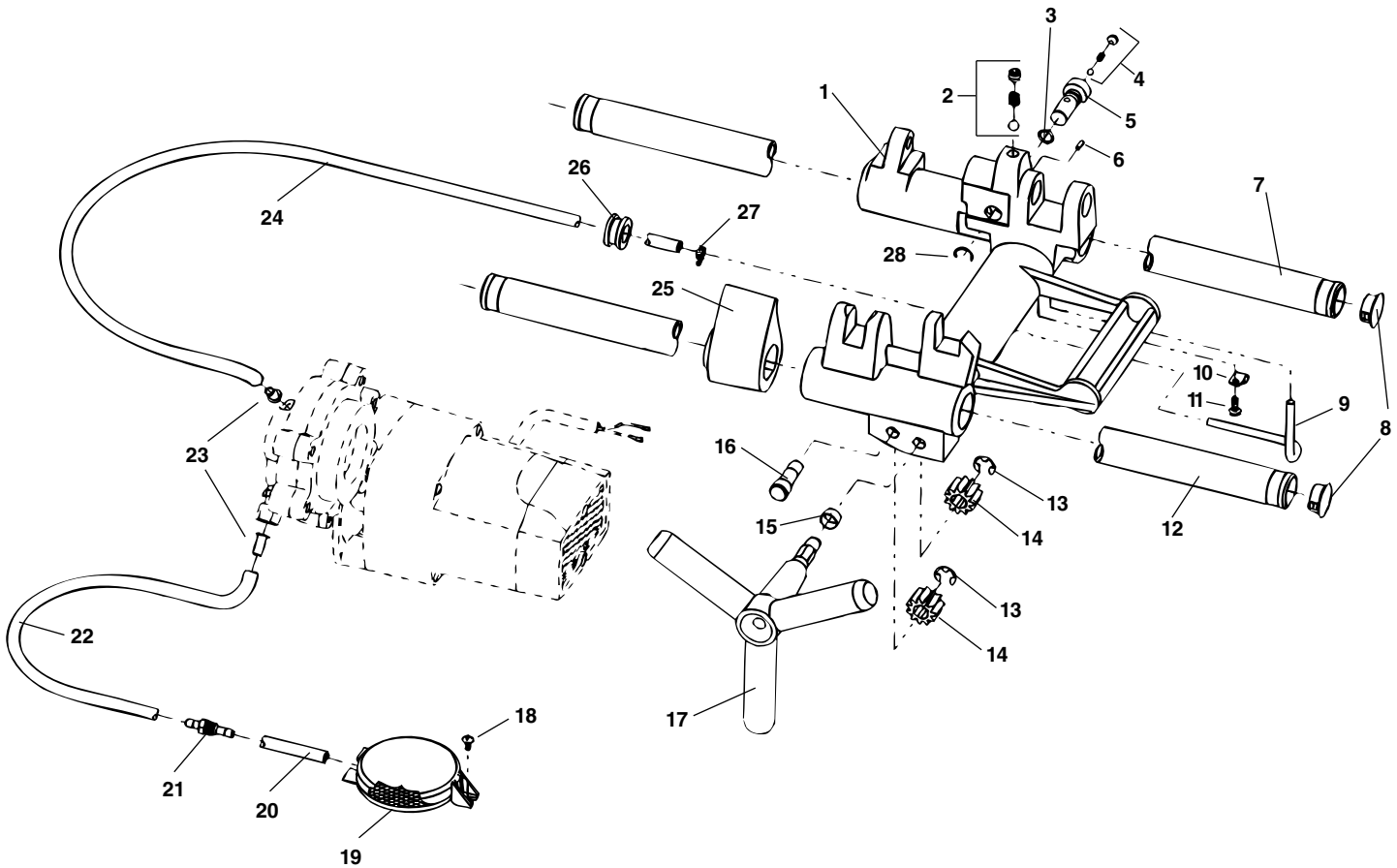

**NOTE: Order parts by Catalog Number only.
DO NOT order by Reference Number.**

Ref. No.	Catalog No.	Description	Ref. No.	Catalog No.	Description
1	58407	Carriage (Includes Ref. #2)	16	58457	Idler Shaft
2	46810	Die Head Detente	17	58427	Plastic Plug (Not Shown)
3	54102	O-Ring	18	58462	Handwheel
4	35307	Oil Pressure Relief	19	45420	Screw
5	54097	Bypass Valve	20	58467	Filter Screen Assembly
6	58417	Roll Pin	21	61897	Oil Tube
7	58422	Rear Rail	22	54142	Bulkhead Fitting
8	58257	Plug (2)	23	58477	Intake Oil Line - 11"
9	58432	Oil Line	24	35117	Tube Insert
10	35062	Clamp	25	58482	Output Oil Line - 25"
11	79965	Screw 10-32 x 1/2"	26	58487	Carriage Stop
12	58437	Front Rail	27	47080	Grommet
13	58442	Retaining Ring	28	35142	Hose Clamp
14	58447	Carriage Pinion Gear		58107	Retaining Ring
15	58452	Bushing			

Carriage and Oil System

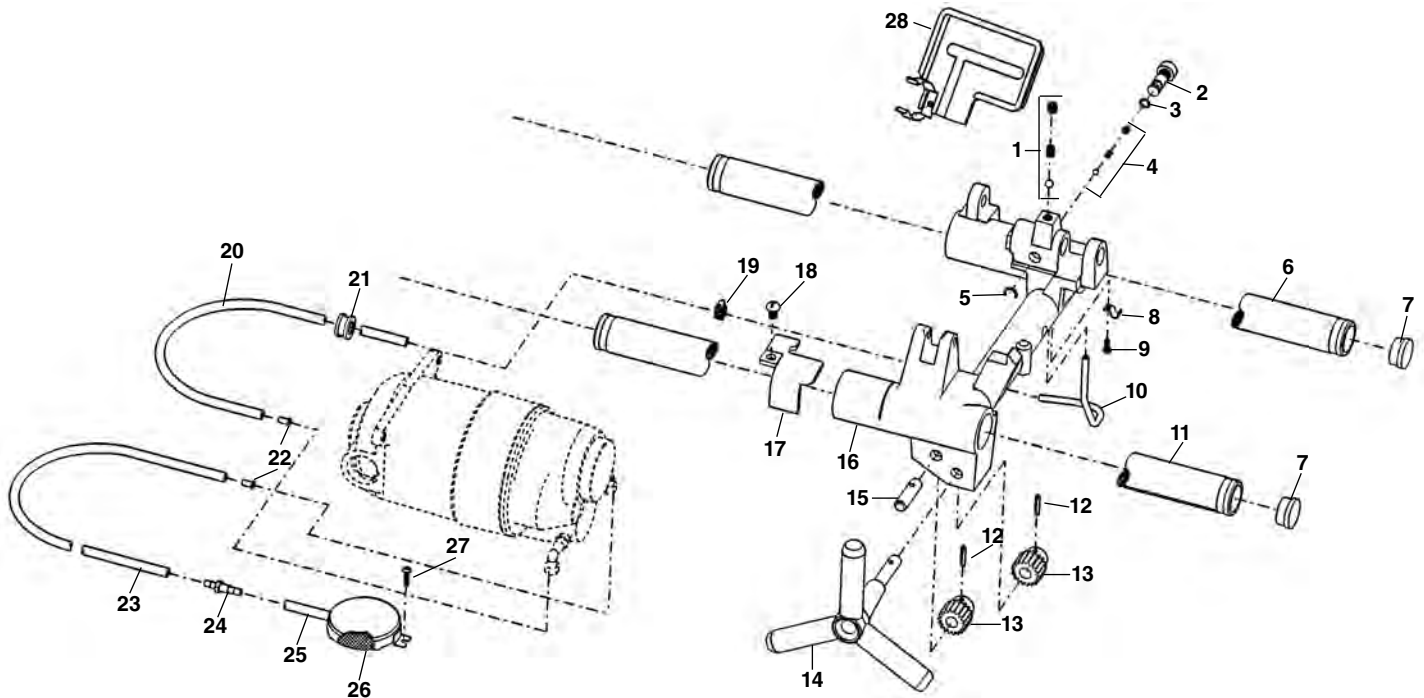

**NOTE: Order parts by Catalog Number only.
DO NOT order by Reference Number.**

Ref. No.	Catalog No.	Description
1	46810	Detente Assembly
2	54097	Spool Valve
3	54102	O-Ring
4	35307	Oil Pressure Relief Set
5	54107	Crescent Ring
6	54112	Rear Rail
7	35162	Rail Plug (4)
8	35062	Oil Line Clamp
9	79965	10-32 x 1/2" Screw
10	35067	Oil Tube
11	54117	Front Rail
12	34342	Roll Pin
13	57097	Pinion
14	35182	Hand Wheel
15	35187	Pinion Idler Shaft
16	54122	Cap Plug (not shown)
16	54127	Carriage
17	54132	Carriage Stop
18	54137	5/16" - 18 x 1/2" Screw
19	35142	Hose Clamp
20	61282	Carriage Oil Line
21	47080	Oil Line Grommet
22	35117	Oil Line Insert
23	54152	Oil Intake Line
24	54142	Bulkhead Fitting
25	61897	Oil Filter Tube
26	58467	Filter Screen Assembly
27	45420	10-24 x 3/8" Screw
28	54517	Drip Pan

Carriage and Oil System - Induction

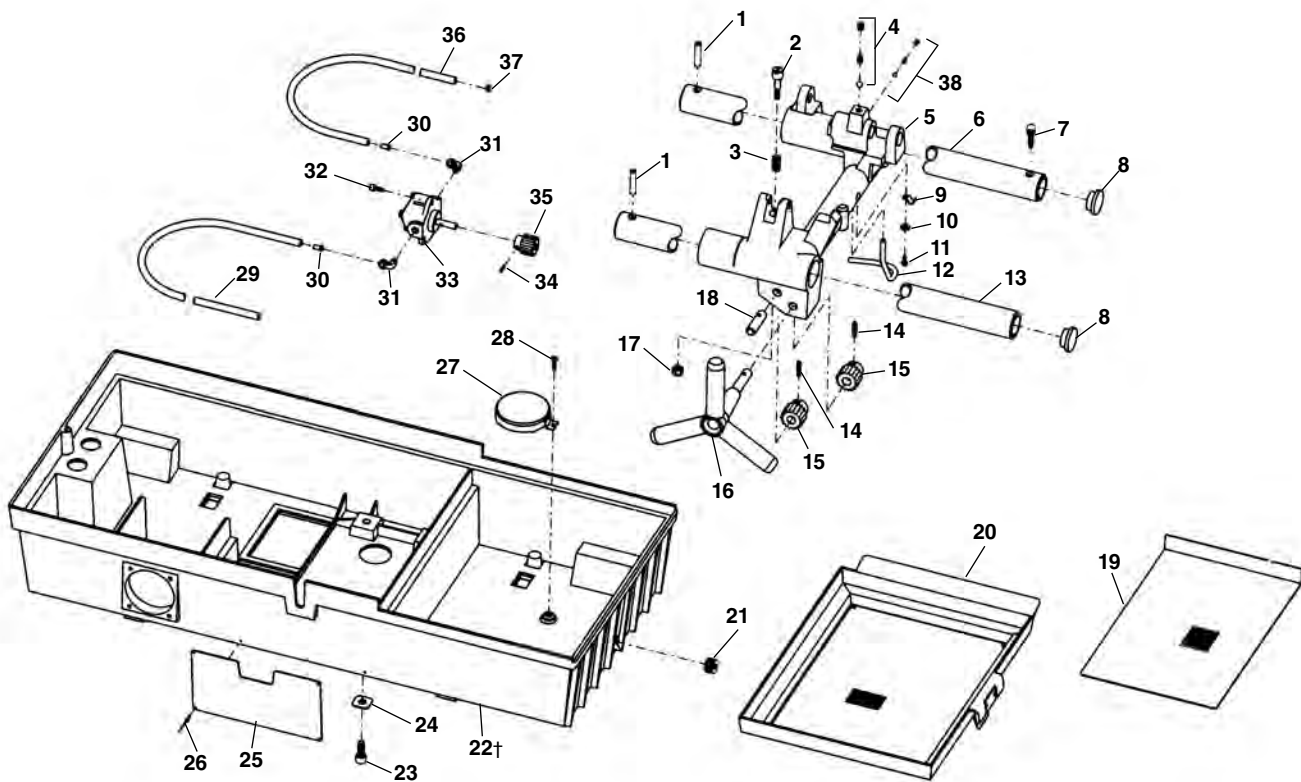

**NOTE: Order parts by Catalog Number only.
DO NOT order by Reference Number.**

Ref. No.	Catalog No.	Description	Ref. No.	Catalog No.	Description
1	34375	Rail Pin (2)	21	48337	Drain Plug 3/4" NPT
2	35042	Stop Bolt	26842	Drain Plug (Rubber-Early Style)	
3	35047	Stop Bolt Spring	22†	59747	Base
4	46810	Detente Assembly	59752	Base (1822-IC)	
5	35147	Carriage (Includes 2, 3, 4, 5, 38)	23	46755	Bolt 3/8" - 16 x 7/8" (4)
6	35057	Rear Rail	24	35107	Square Washer (4)
7	34425	Screw 5/16" - 18 x 3/8"	25	36612	Warning Plate 60Hz
8	35162	Rail Plug (2)	26	35222	Pop Rivet (2)
9	35062	Oil Line Clamp	27	58467	Oil Screen Assembly
10	45365	Washer #10	28	26797	Oil Screen Screw 10-32 x 5/16"
11	79965	Screw 10-32 x 1/2"	29	35112	Oil Intake Line 30"
12	35067	Oil Tube	30	35117	Oil Line Insert (2)
13	35167	Front Rail	31	35122	90 Degree Fitting (2)
14	34342	Roll Pin 3/16" x 15/16" (2)	32	32145	Bolt 1/4" - 20 x 1/2" (3)
15	59092	Carriage Pinion (2)	33	39162	Oil Pump
16	35182	Handwheel	34	39820	Pin
17	75110	Stop Nut 5/16" - 18	35	35197	24 T Pump Gear - 60 Hz
18	35187	Pinion Idler Shaft	36	35137	Oil Supply Line 40"
19	35192	Lower Screen	37	35142	Hose Clamp
20	35097	Draw Tray Assembly	38	35307	Oil Pressure Relief

† 20133 Switch required if changing from older style base. New base has smaller 2 1/2" diameter opening for switch.